

X TRI
DENTAL IMPLANTS

ELYSEEDENTAL
Modern Dental Group



matrix[®] INTRO-
DUCTION
LINE



#1 DIGITAL IMPLANT
COMPANY

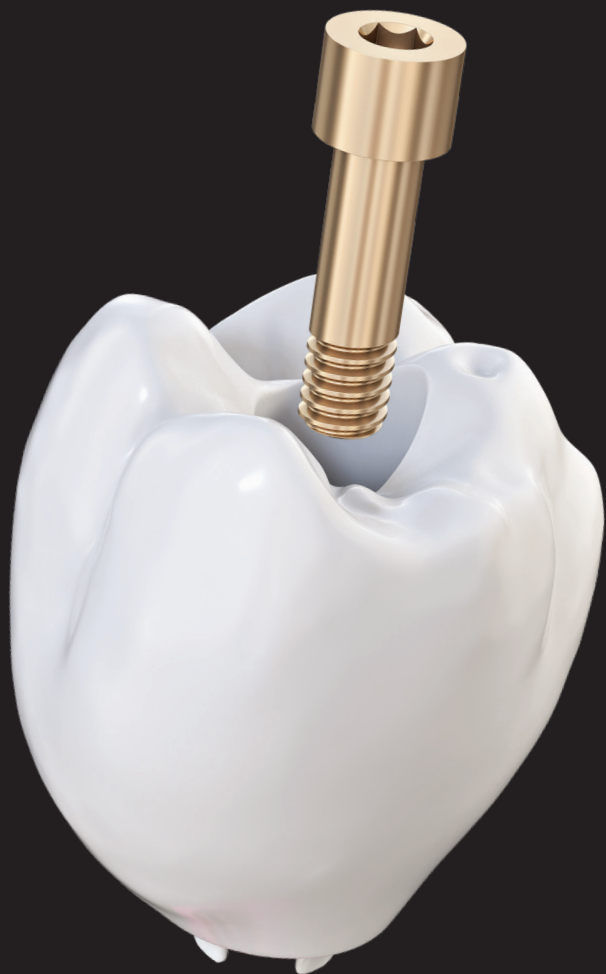

The world's first
implant approved
for full digital
restorations
without abutment.

matrix[®]

NO
ABUTMENT.

NO
CEMENT.

NO
LIMITS.

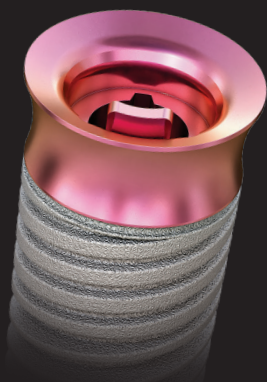

The **matrix**[®] is the world's first dental implant approved for fully digitally single and multi-unit restorations directly on the implant without the use of the abutment. This unique implant connection has been specifically designed for the new digital manufacturing technologies such as CAD/CAM milling or 3D printing.

Unleash the benefits that
will *change your workflow*



Esthetics



Immediacy

matrix[®]



Quality



Simplicity

Explore the benefits

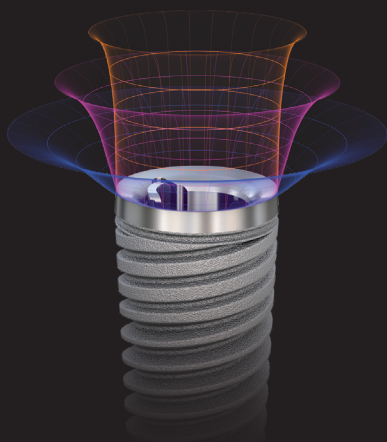

Esthetics

+ Design Flexibility
(emergence profile)



+ Natural colour with
zirconia directly on
the implant



+ Angulated screw-
channel up to 20°



+ Stronger than
abutments



+ Higher precision



+ No cement: 100% screw
retained restorations



+ No risk of debonding





Quality

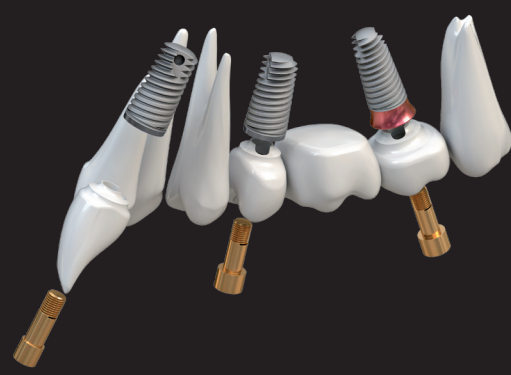



Simplicity

- + Material & indication flexibility 
- + Material & inventory cost savings 
- + Streamlined portfolio & less components 
- + Up to 100° between implants 

- + Time saving through elimination of manual work 
- + Customized & consistent emergence profiles throughout the whole treatment process 
- + Immediate full digital local workflow (chairside or labside) 

Immediacy

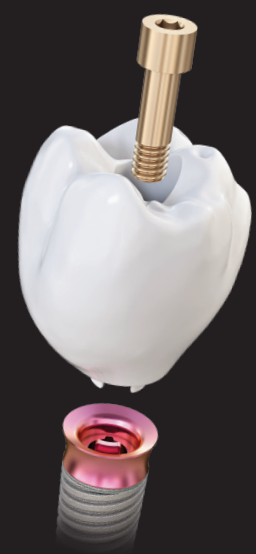

Our vision of the future digital workflow.

In the past years prosthetic manufacturing has completely changed and new materials were developed. However, the implant interfaces has remained unchanged for the last 30-40 years, leading to a mismatch between implant connections and modern prosthetic manufacturing.

TRI® vision was to connect these two worlds by thinking the other way around. In regards to the precision of today's milling technologies and from a CAD/CAM productions' point of view we have created the **matrix®** implant system, where no abutment and cementation is needed.

A technology ahead of its time, prepared to bring digital implantology to a new dimension.

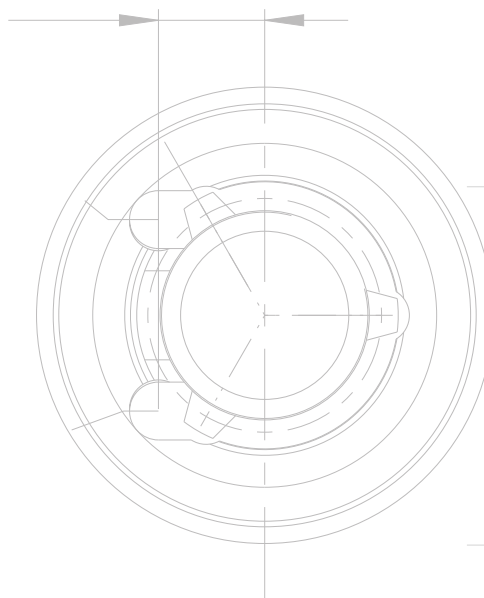

Three key challenges in digital implantology nowadays.

Our solution.

The ability to mill the restoration directly on top of the implant.

The challenge #1

The achievement of same or higher industrial precision of abutments manufacturing in standard chairside & labside milling machines

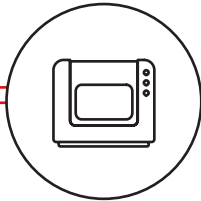

Our solution #1

Dedicated milling strategies combined with a connection design that can be milled in an easy and forgivable way.

The challenge #2

A implant connection suitable for modern materials such as zirconium-dioxide.

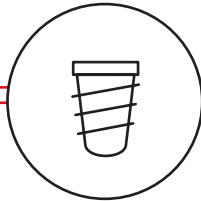

Our solution #2

To design the worlds first connection that respects latest science and biomechanical properties of zirconia.

The challenge #3

The achievement of same or higher mechanical stability compared to TRI® Classic Line.

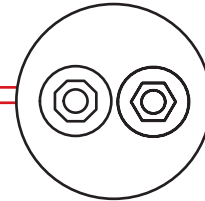

Our solution #3

Getting stronger wall thickness in restoration by removing Ti-Bases.

Discover the unique features of the **matrix**[®] implant system

matrix[®] MillFit
designed to be milled locally
P. 14

matrix[®] SlimNeck
for increased biological width
P. 16

TRI[®] +
Connection to all open digital workflows with
labside and chairside milling.
P. 26

TRI[®] Performance Concept
10 years clinically proven implant surface and
tapered biomechanical design.
P. 24

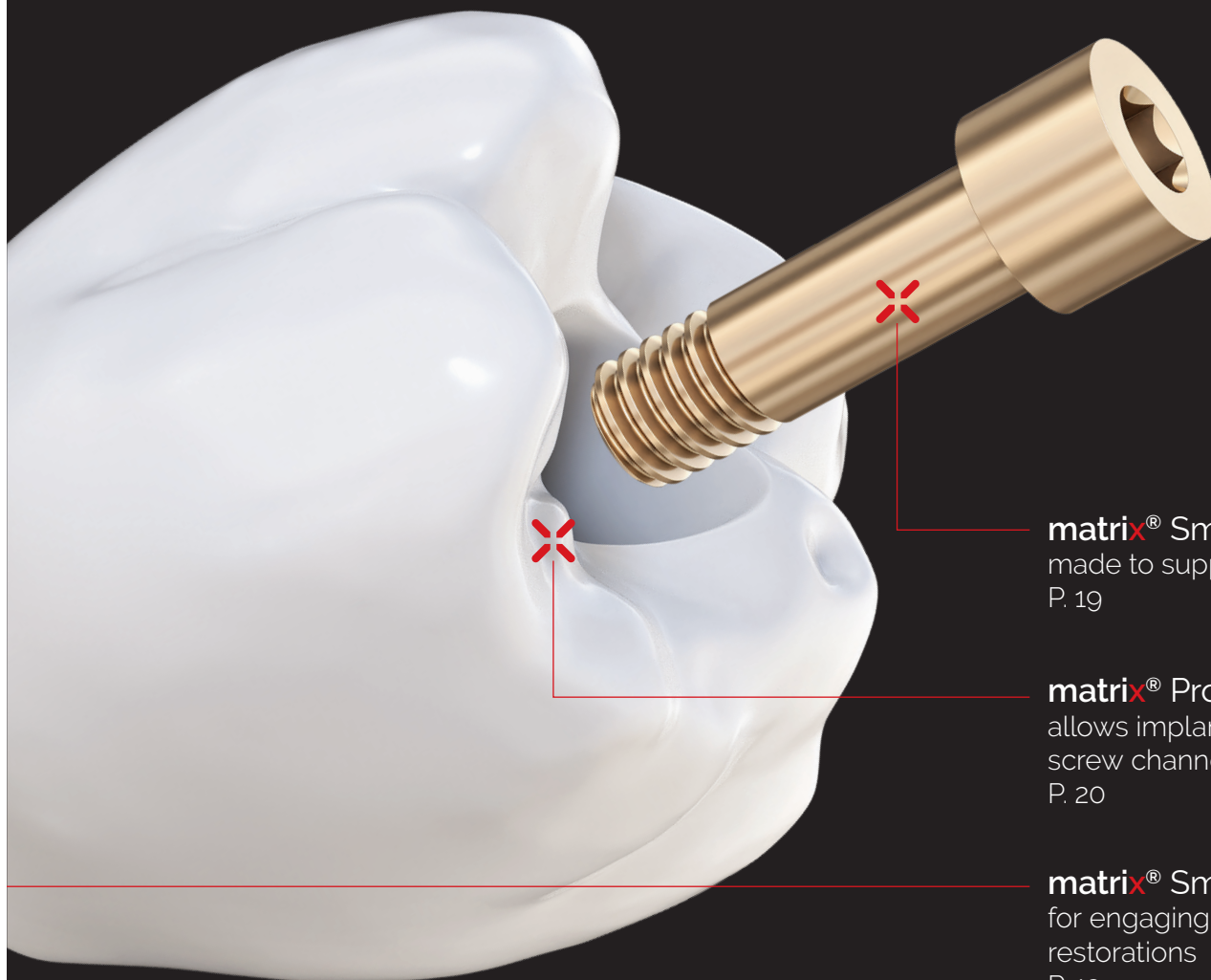

matrix[®] PowerBase
designed for Zirconia on Titanium
P. 10

matrix[®] SmartBolt
made to support all materials
P. 19

matrix[®] ProFlex
allows implant placement and
screw channel freedom
P. 20

matrix[®] SmartLock
for engaging and non-engaging
restorations
P. 13

matrix[®] PowerBase

A World-class connection designed to support zirconia on titanium

matrix[®] PowerBase and its 20° degree internal flat connection, maximizes the surface area to support prosthetic restoration directly on the implant. The world-class connection provides self-centering properties for ideal handling and fit and allows high divergences (50°) between implants.

- + Platforms P37 and P45 with significantly larger area than a Ti-Base
- + Optimal for force transmission between implant and crown
- + Support direct restoration with all materials

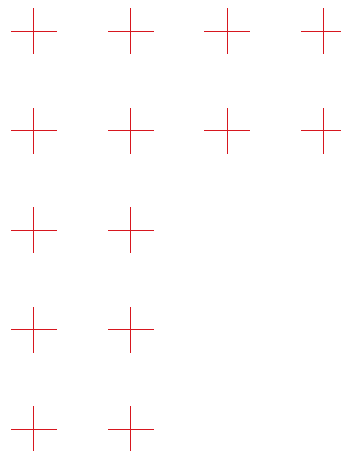

Platforms available



Bone-Level
P37 (ø3.7mm)



Bone-Level
P45 (ø4.5mm)



Tissue-Level
P37 (ø3.7mm)

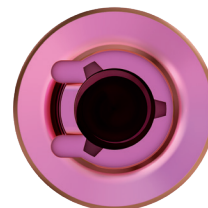

Tissue-Level
P45 (ø4.5mm)

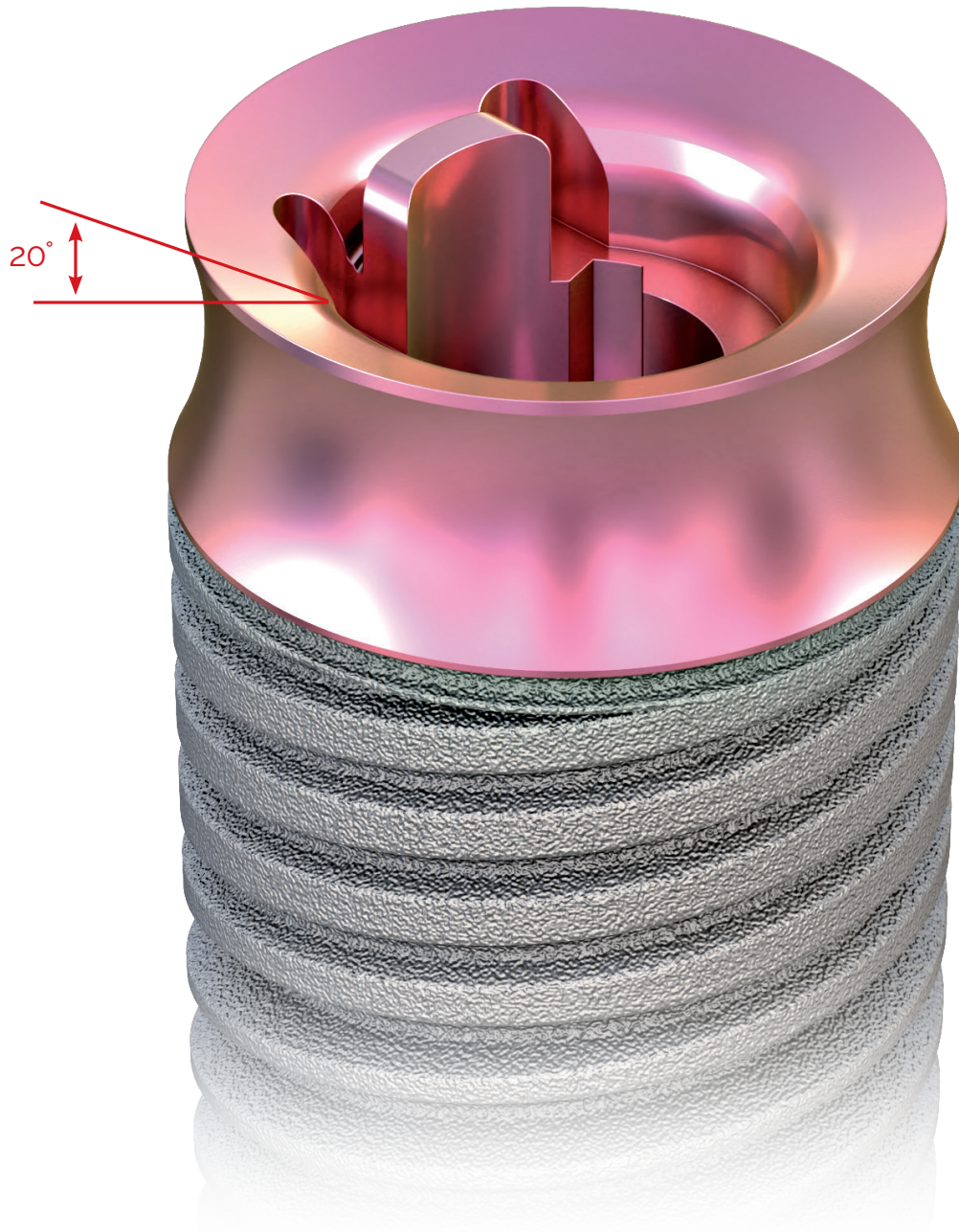

Engaging

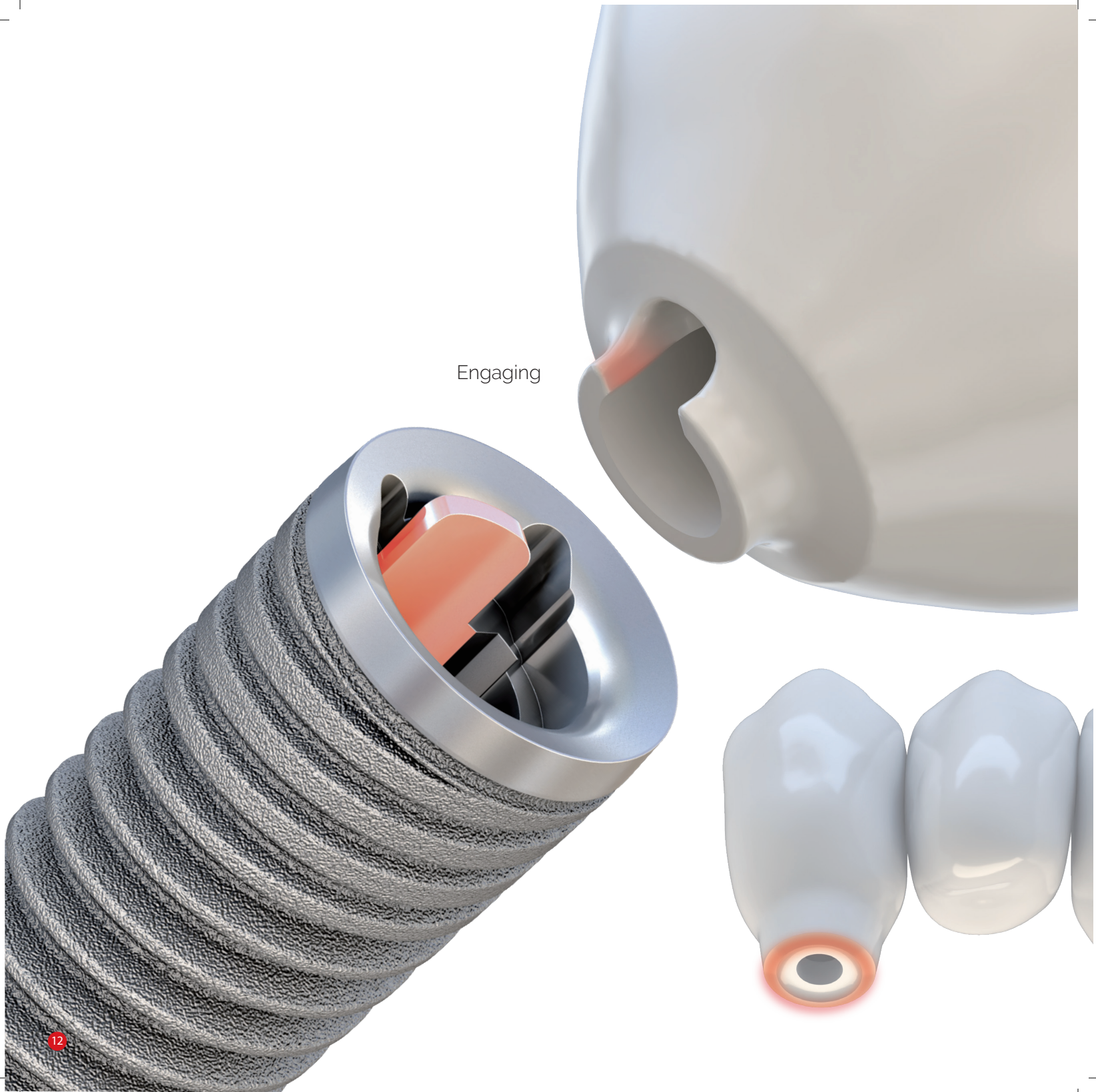

A versatile connection for Engaging and Non-Engaging restorations

matrix[®] SmartLock is a self-locking system for automatic positioning, which allows only one single position for crowns and a non-engaging position for multi-unit restorations. It consists of two big vertical rotation blockers with 1.2mm distance for easy milling of the prosthetics and tactile feedback.

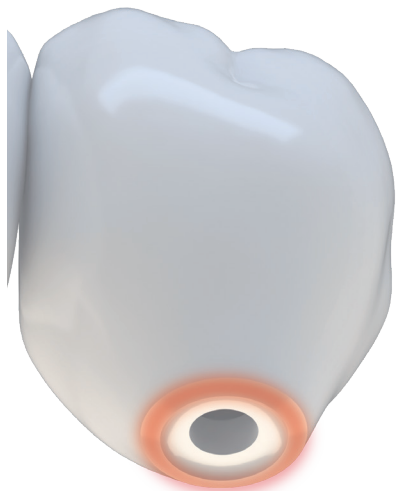

Non-Engaging

- + Highly precise fit through vertical guidance
- + Self-locking system for automatic positioning (one position)
- + Allows for engaging as well as non-engaging connections based on milling strategy.



Connection designed for easy and highly **precise** **local milling.**

matrix[®] MillingFit achieves easy and precise milling with standard tools through dedicated milling strategies. A compact connection between implant, screw and crown with no hollow spaces and an interface surface roughness which rises above industrial abutment manufacturing.

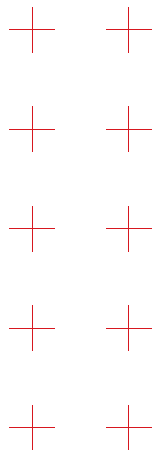

- + Standard drills and dedicated CAM strategies for **matrix[®]**
- + Achieves 0.2 μ of surface roughness for all materials
- + Better than industrial abutment manufacturing (Ra 0.6 μ)

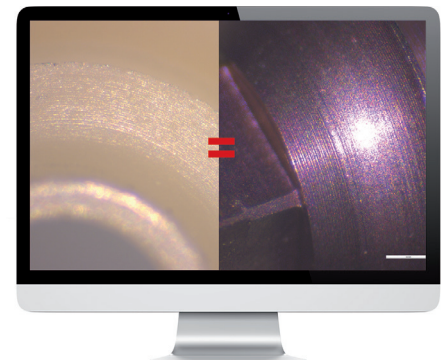
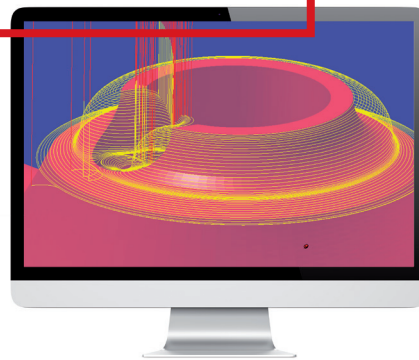



Dedicated milling strategy
for **matrix**[®] connection.

Profiles for increased biological width.

Concave tissue-level emergence profile for infinitely more esthetics

The **matrix**[®] tissue-level implant comes with a modern emergence profile and a unique concave design. The implant line features a pink anodized neck for optimized translucency and supports modern surgical procedures, such as sub-crestal placements. Ideal for minimal invasive procedures and an increased biological width, **matrix**[®] is better than ever in guaranteeing high esthetic results and longevity.



Bone-Level platform switching

The **matrix**[®] bone-level implant features a 20° shoulder for high divergence bridge restorations and integrates platform-switching to preserve the crestal bone.



Tissue-Level

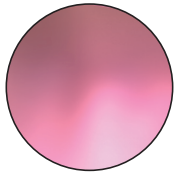

Pink anodization for tissue management

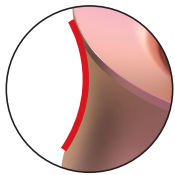

Concave design for increased biological width

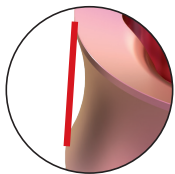

Thanks to reverse-taper design bone doesn't get re-exposed

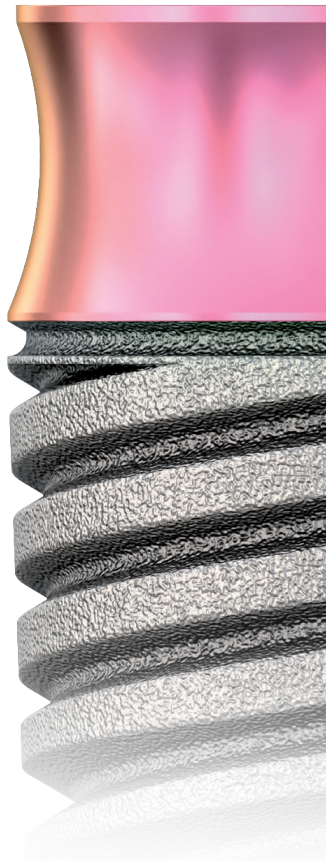

Bone-Level

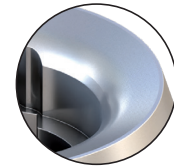

The 20-degree shoulder for high divergence bridge restorations

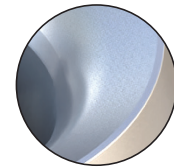

Platform switching for stable crestal bone levels.

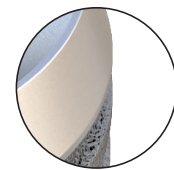

0,5mm machined neck in the crestal area.

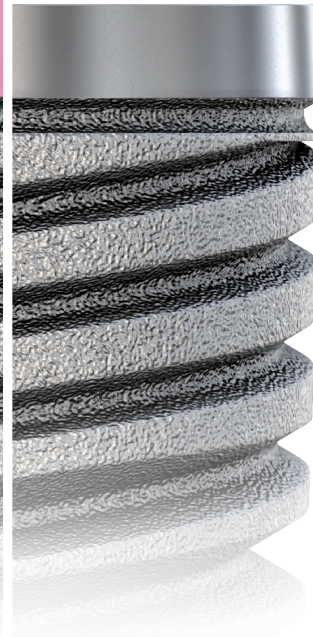

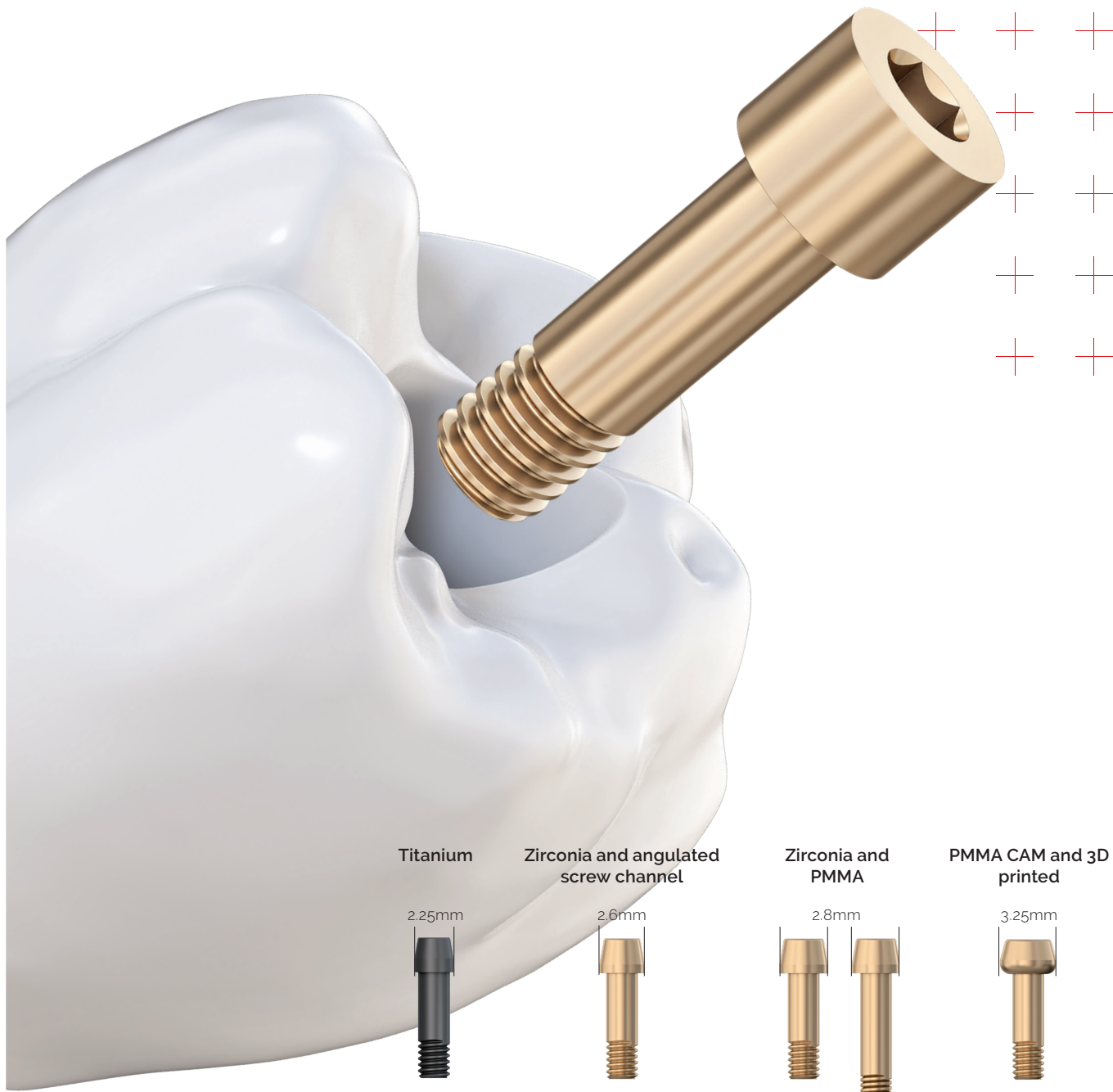

Titanium

2.25mm



flat horizontal
screw head

Zirconia and angulated
screw channel

2.6mm



flat horizontal
screw head

Zirconia and
PMMA

2.8mm

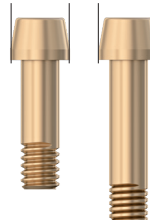

flat horizontal
screw head

PMMA CAM and 3D
printed

3.25mm

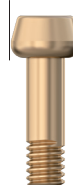

round screw
head

Intelligent screw system for all materials and indications.

matrix[®] SmartBolt consists of three different screw heads, designed for material-specific milling strategies to ensure a precise fit. The specially treated screw surface guarantees increased hardness, scratch-resistance and fatigue strength. The sterile screws are gold anodized for higher esthetics with translucency zirconia.

- + Three different screw heads for dedicated indications and materials
- + Special Titanium (grade 23) for maximal strength
- + Screw-head is designed to allow for ideal material-specific milling strategies.

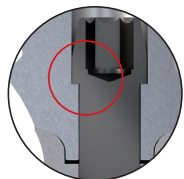
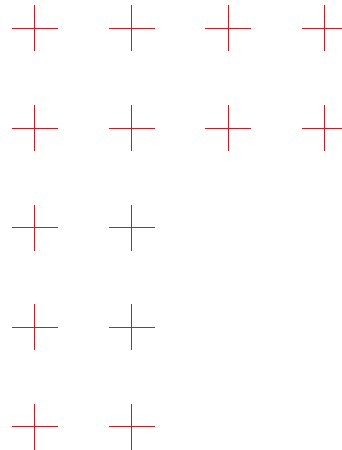

Metals

Narrow screw-head for metal restorations to minimize diameter of screw-access hole

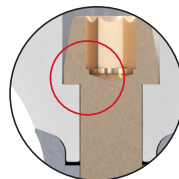

Ceramics

Medium-size screw-head optimized to support zirconium.

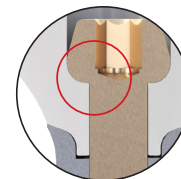

Polymers

Round screw-head to support provisional polymers with ideal force distribution.

Highest design flexibility in local production

matrix[®] ProFlex allows implant divergence up to 50° and 20° angled screw channels. The compact design facilitates the placement of fully anatomical crowns without adjustment and supports easy impression taking for angulated implants.



- + Screw channel up to 20° degree angulation all around
- + Occlusal esthetics in anterior region
- + Better handling in posterior region

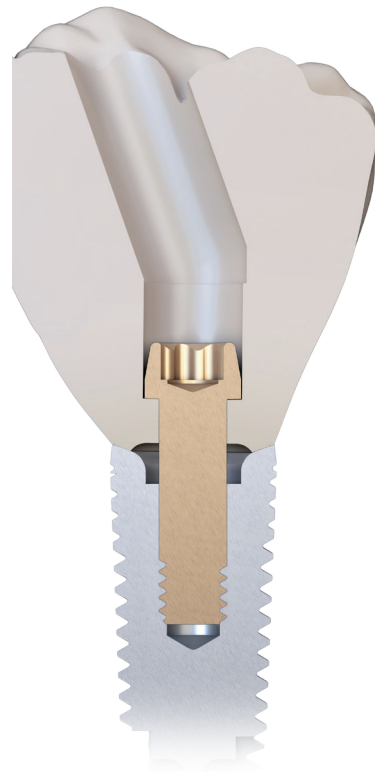

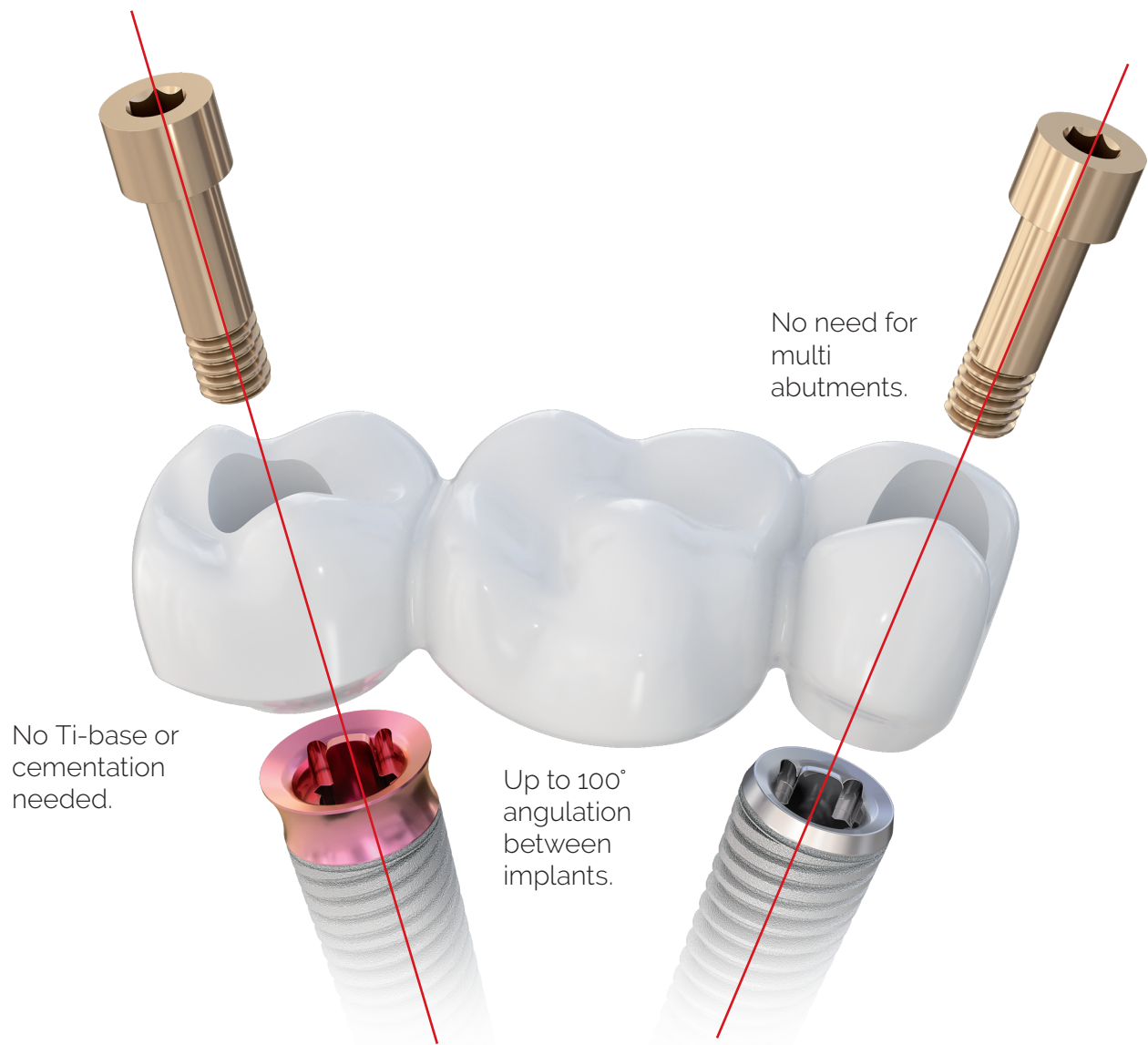

No Ti-base or
cementation
needed.

Up to 100°
angulation
between
implants.

No need for
multi
abutments.

Allows implant divergence up to 50°
and 20° angled screw channels.

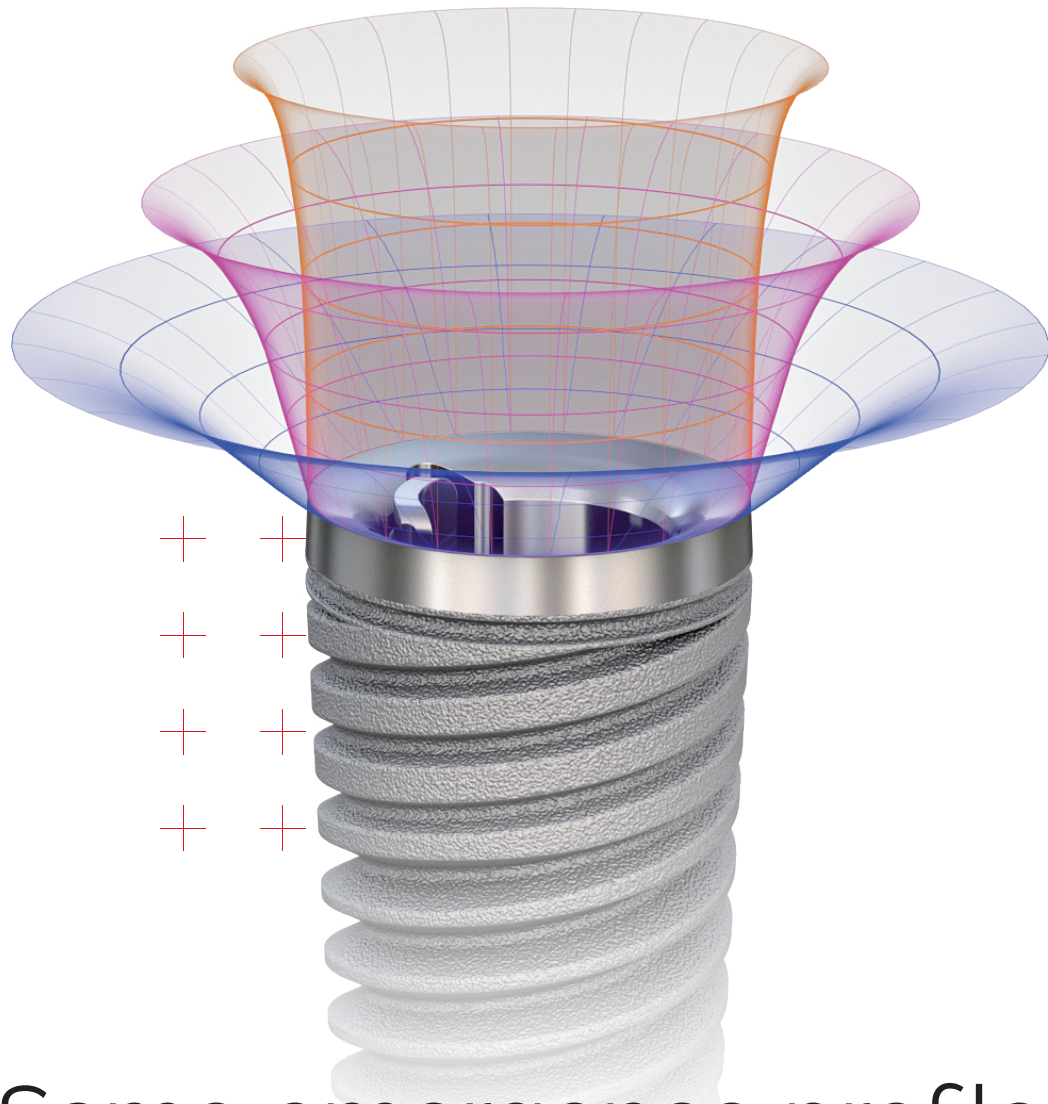

Same emergence profile
for healing, provisional and final
restoration.

Patient-specific & individual emergence profile

matrix[®] allows to create 100% digital, chairside manufactured patient-specific emergence profiles by considering the biological shape and transferring the design 1:1 throughout the whole treatment process (healing, provisional and final restoration). With matrix[®] any design and shape on any material is possible and guarantees a full-anatomic and high esthetic gingiva management.

- + Production of personalized healing collar from any material
- + Immediate and efficient through chairside manufacturing option
- + High esthetic gingiva management

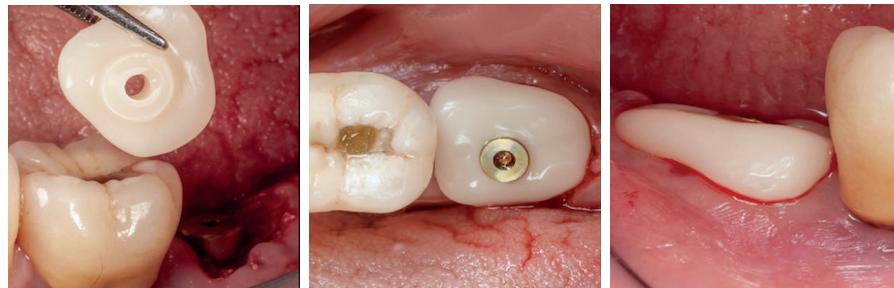
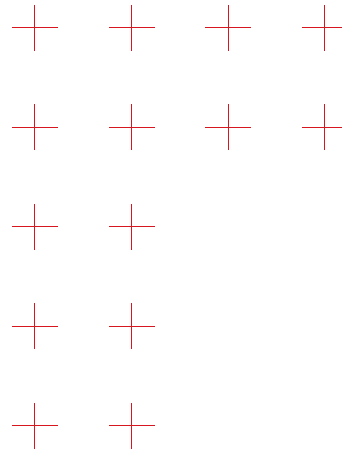

Dr. Ramón Gómez Meda (Spain)

TRI

Performance
concept

TRI[®] BoneAdapt for immediate stability

Platform Switch Neck Design — to shift the biological width horizontally and stabilize the crestal bone

- + **Crestal thread design**
with square thread pattern to protect the cortical bone
- + **Body thread design** (60 degrees)
to enhance bone surface area in the spongiosa for optimal bone-to-implant contact
- + **Apical thread design** (45 degrees)
with increased sharpness for immediate primary stability
- + **Round Apex**
to protect the Schneiderian Membrane

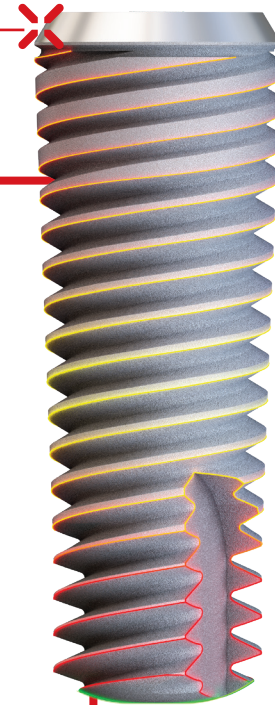

Triple-lead threads

Three independent threads start 120° apart and spiral around the implant body and end on the crestal vertical groove. Triple threads provide a lead of 1.8 mm per rotation as an average.

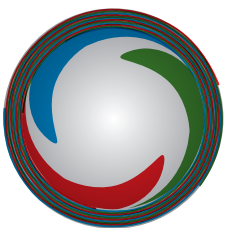

TRI[®] SBA Surface for predictable osseointegration

The TRI[®] SBA (sandblasted, large grit, acid-etched) surface is one of the industry gold standards for more than 20 years. It is created by blasting the implant surface under pressure with corundum particles. In the final step the surface is acid-etched twice in order to attain a medium roughness.

Machined implant neck

The bone level implants feature a 0,5 mm machined neck in the crestal area.



Bone-Level

Gingiva coloured implant collar

The tissue level implant features a 1,8mm machined implant collar for optimal esthetic results in the posterior area.



Tissue-Level

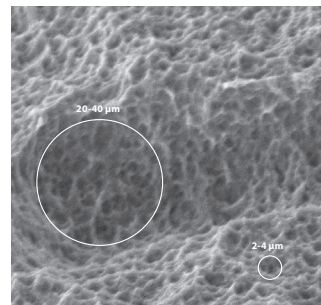

Surface structure

A macrostructure of 20-40 µm and a micro structure of 2-4 µm as an ideal basis for excellent osseointegration. This structure has been proven by numerous clinical studies for this surface type.

TRI⁺ Open System

Connection to all **open digital workflows** with labside and chairside milling

TRI⁺ Digital Solutions guarantees a universal implant open interface to leading technology partners in digital dentistry. In contrast to numerous digital locked systems, TRI⁺ helps to create more transparency and eliminate all barriers to their respective treatments. TRI⁺ Digital Solutions offers a wide range of indications via 3D planning, guided surgery, CAD abutments, CAD / CAM screw-retained and cement-retained restorations or modern treatments

+ 3D-Planning & Guided Surgery

+ CAD/CAM screw-retained
crowns and bridges

+ CAD/CAM screw-retained
bars and bridges

5 Step Workflow

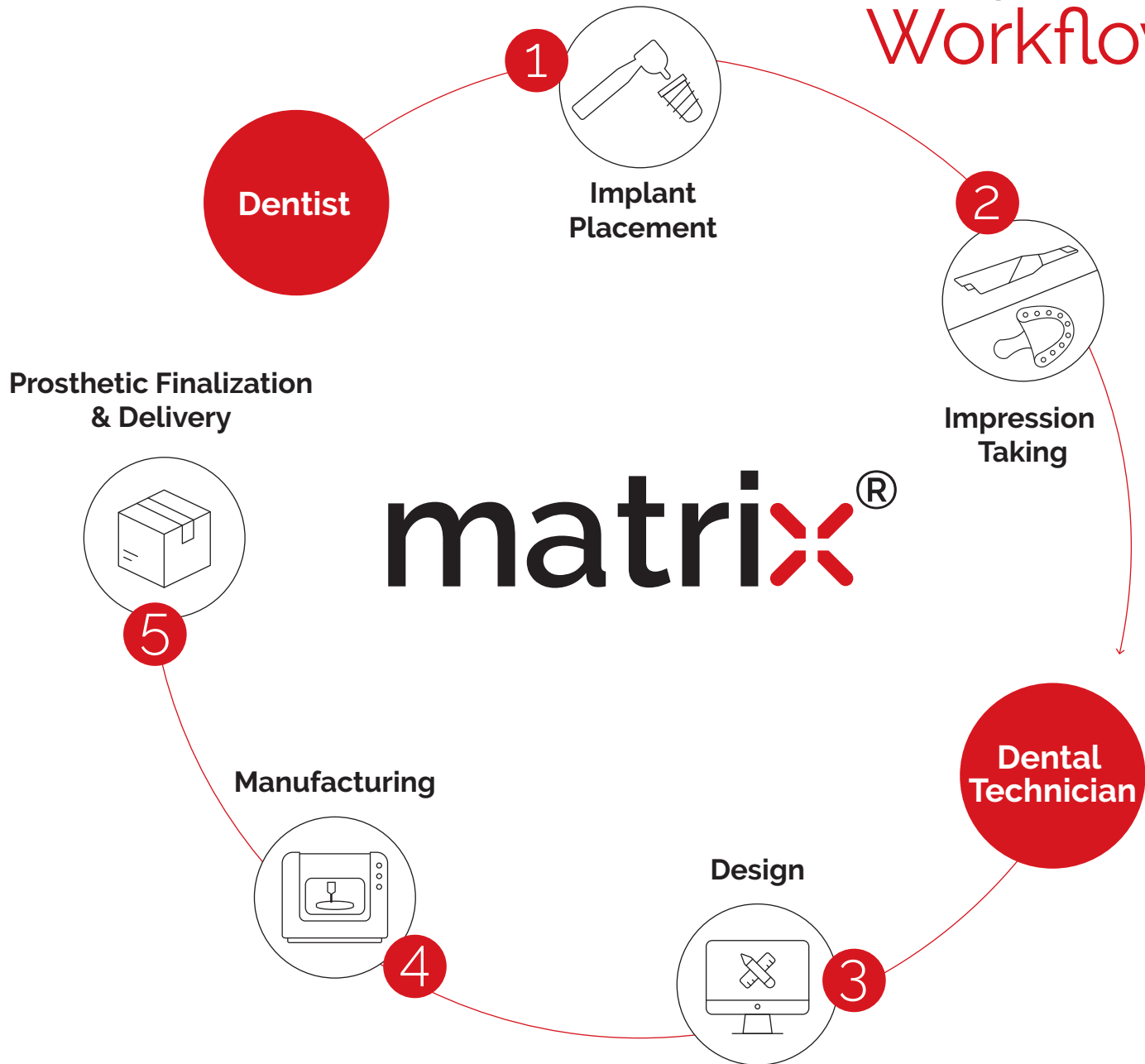

Portfolio Overview

BONE-LEVEL



3.75mmD Implant	4.1mmD Implant	4.7mmD Implant
8mmL	6.5mmL	6.5mmL
10mmL	8mmL	8mmL
11.5mmL	10mmL	10mmL
13mmL	11.5mmL	11.5mmL
16mmL	13mmL	13mmL
	16mmL	16mmL

TISSUE-LEVEL



3.3mmD Implant	3.75mmD Implant	4.1mmD Implant	3.75mmD Implant	4.1mmD Implant	4.7mmD Implant
6.5mmL	6.5mmL	6.5mmL	6.5mmL	6.5mmL	6.5mmL
8mmL	8mmL	8mmL	8mmL	8mmL	8mmL
10mmL	10mmL	10mmL	10mmL	10mmL	10mmL
11.5mmL	11.5mmL	11.5mmL	11.5mmL	11.5mmL	11.5mmL
13mmL	13mmL	13mmL	13mmL	13mmL	13mmL
	16mmL	16mmL	16mmL	16mmL	16mmL

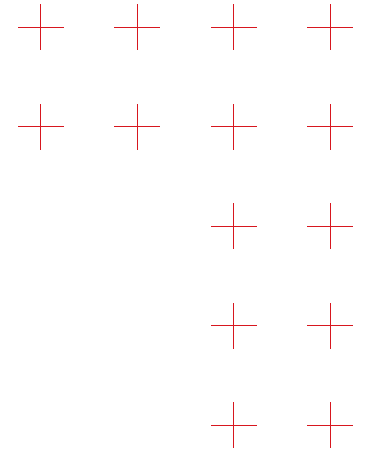

The World's finest
implant system

Case Overview



Dr. Aleksandru Ionescu



Extraction of tooth 24

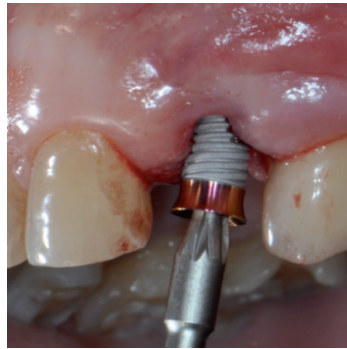

Immediate **matrix**[®] Tissue-Level Implant insertion



Final monolithic CAM manufactured crown with angulated screw channel. Natural tooth design copied from the pre OP scan



Perfect fit of final restoration



Dr. Joel Teles

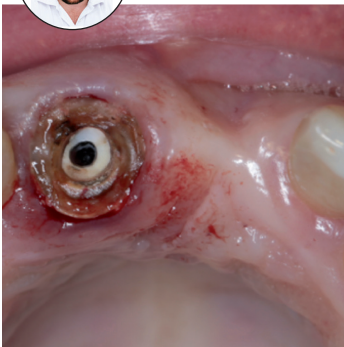

Initial Situation



Tissue healing after 10 weeks of PMMA immediate temporary restoration in situ

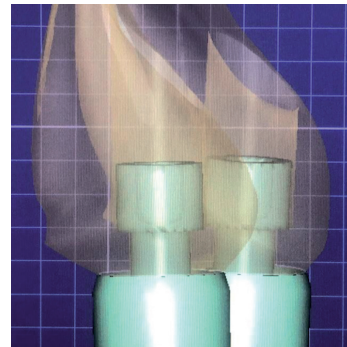

Designing of two single monolithic zirconia crowns (cut-back technique)



Final restoration, 100% screw retained. Two veneered monolithic crowns (cut-back technique)



Dr. Ramón Gómez Meda

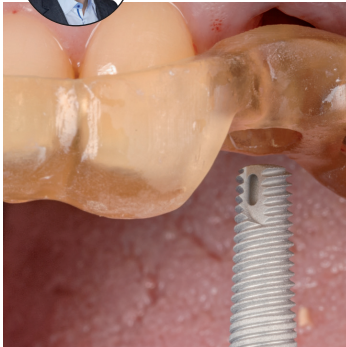

Immediate **matrix**[®]
Tissue-Level Implant
insertion



Chairside milling of
an esthetical PMMA
temporary crown

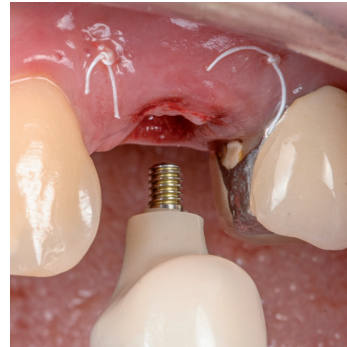

Insertion of immediate
chairside PMMA
temporary crown



Perfect fit of PMMA
temporary crown



Dr. Ivan Peev



Initial situation

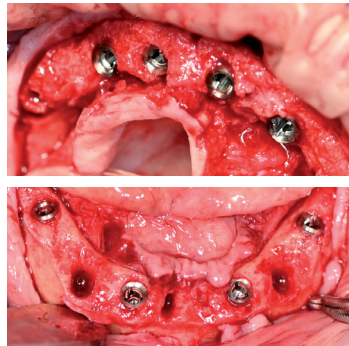

Immediate placement of
6 Bone-Level in upper
Jaw and 4 Tissue-Bone
implants in lower jaw

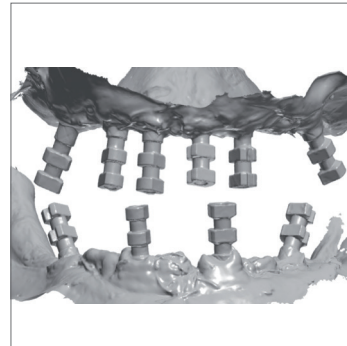

Intra oral scan for
direct design of CAM
chairside PMMA
temporary
full-arch restoration



PMMA temporary
restoration in situ



TRI Dental Implants Int. AG
Switzerland
00800 3313 3313
www.tri.swiss



TRI® Dental Implants, the TRI® Dental Implants logotype and all other trademarks used in this document are, if nothing else is stated or is evident from the context in a certain case, trademarks of the TRI Dental Implants Int. AG.

TRI® **matrix**® Introduction Brochure EN 2021-08/01



CE 0297 | FDA Registered